



**NUS**

National University  
of Singapore

EE5104 ADAPTIVE CONTROL SYSTEM AY2009/2010  
CA2 MINI-PROJECT

---

## Sliding Mode Control

---

*Name:*

PHANG Swee King  
A0033585A

*Lecturer:*

A/Prof. W. K. Ho

October 5, 2010

## **Abstract**

In this project, a sliding mode controller is designed to a linear plant with non-linear disturbances. The performance of the designed controller is then verified via simulation using MATLAB and Simulink. Then, the *sign* function in the designed controller will be replaced by a *sat* function, and the performance of the new controller will be investigated. Finally, some conclusion remarks will be made according to the simulation results.

# Contents

<b>1</b>	<b>Sliding Mode Controller Design</b>	<b>3</b>
1.1	Plant Analysis . . . . .	3
1.2	Controller Design . . . . .	3
<b>2</b>	<b>Simulation</b>	<b>6</b>
2.1	Simulation Parameters . . . . .	6
2.2	Simulation Results . . . . .	7
<b>3</b>	<b>Smooth Control Law</b>	<b>13</b>
3.1	Control Law Design . . . . .	13
3.2	Simulation . . . . .	13
<b>4</b>	<b>Source Codes</b>	<b>19</b>

# Chapter 1

## Sliding Mode Controller Design

Sliding mode control is a special version of an on-off control. The key idea is to apply strong control action when the system deviates from the desired behavior. The motivation of this controller is to introduce the Lyapunov function

$$V(x) = \frac{\sigma^2(x)}{2}$$

where  $\sigma(x)$  is the switching surface of the system. A controller will be designed in a way such that

$$\dot{V}(x) < 0$$

for all  $t$ . By then, the controlled system response will then be guaranteed to reach the switching surface, where  $\sigma(x) = 0$ , in finite value of  $t$ .

### 1.1 Plant Analysis

In this setup, consider the system

$$\begin{aligned}\dot{x}_1 &= ax_1 + bu + d \\ \dot{x}_2 &= x_1\end{aligned}$$

The switching surface is then defined by

$$\sigma(x) = c_1x_1 + c_2x_2$$

where  $a$ ,  $b$ ,  $c_1$ , and  $c_2$  are known a priori, and  $d$  is a bounded disturbance with  $|d| \leq d_{max}$ . We need to design a variable structure controller such that  $x = 0$  is an asymptotically stable solution.

### 1.2 Controller Design

We rewrite the system in the state-space structure

$$\begin{aligned}\dot{x} &= \begin{pmatrix} a & 0 \\ 1 & 0 \end{pmatrix} x + \begin{pmatrix} b \\ 0 \end{pmatrix} u + \begin{pmatrix} 1 \\ 0 \end{pmatrix} d \\ &= f + gu + hd\end{aligned}\tag{1.1}$$

where  $x = \begin{pmatrix} x_1 \\ x_2 \end{pmatrix}$ ,  $f = \begin{pmatrix} a & 0 \\ 1 & 0 \end{pmatrix} \begin{pmatrix} x_1 \\ x_2 \end{pmatrix} = \begin{pmatrix} ax_1 \\ x_1 \end{pmatrix}$ ,  $g = \begin{pmatrix} b \\ 0 \end{pmatrix}$ , and  $h = \begin{pmatrix} 1 \\ 0 \end{pmatrix}$ . The switching surface is then defined by

$$\sigma(x) = c_1x_1 + c_2x_2 = p^T x \quad (1.2)$$

where  $p^T = (c_1 \ c_2)$ .

To determine a control law that keeps the system on  $\sigma(x) = 0$ , we introduce the Lyapunov function

$$V(x) = \frac{\sigma^2(x)}{2} \quad (1.3)$$

The following control law design will ensure that  $\dot{V}(x) < 0$  for all  $t$  except when  $\sigma(x) = 0$ .

## Control Law

From (1.1) to (1.3),

$$\begin{aligned} \dot{V}(x) &= \sigma \dot{\sigma} \\ &= \sigma p^T \dot{x} \\ &= \sigma(p^T f + p^T g u + p^T h d) \end{aligned} \quad (1.4)$$

We choose the control law

$$u = -\frac{p^T f}{p^T g} - \frac{p^T h d_{max} + \mu}{p^T g} \text{sign}(\sigma(x)) \quad (1.5)$$

such that (1.4) becomes

$$\begin{aligned} \dot{V}(x) &= \sigma \left( p^T f + p^T g \left[ -\frac{p^T f}{p^T g} - \frac{p^T h d_{max} + \mu}{p^T g} \text{sign}(\sigma) \right] + p^T h d \right) \\ &= \sigma(p^T h d - (p^T h d_{max} + \mu) \text{sign}(\sigma)) \\ &= \sigma p^T h d - |\sigma| (p^T h d_{max} + \mu) \\ &= -p^T h (|\sigma| d_{max} - \sigma d) - \mu |\sigma| \end{aligned} \quad (1.6)$$

## Stability Analysis

We know  $|\sigma| d_{max} \geq \sigma d$  for any value of  $\sigma$ . Thus, from (1.6), we have  $\dot{V}(x) < 0$  for all  $\mu > 0$ . Convergence of  $V(x)$  to 0 is guaranteed.

When the output reaches the switching surface,  $\sigma = 0$ , the dynamic of the system is determined by the value of  $p^T$ . In this project,

$$\begin{aligned} \sigma = p^T x &= c_1x_1 + c_2x_2 \\ &= c_1\dot{x}_2 + c_2x_2 = 0 \end{aligned} \quad (1.7)$$

Solving this differential equation, we will get

$$x_2(t) = e^{-(c_2/c_1)t}x_2(0) \tag{1.8}$$

$$x_1(t) = -\frac{c_2}{c_1}e^{-(c_2/c_1)t}x_2(0) \tag{1.9}$$

We see that, as long as  $c_1$  and  $c_2$  having the same *sign*, or in other words, the equation  $P(s) = c_1s + c_2$  has all its roots in the left-half plane, the state  $x$  will converge to 0 exponentially, regardless of the initial condition,  $x(0)$ .

# Chapter 2

## Simulation

In this chapter, a simple simulation is carried out using MATLAB and Simulink to verify the performance of the designed sliding mode controller.

### 2.1 Simulation Parameters

As given by the experiment sheets, the plant parameters are

$a$	2
$b$	1
$c_1$	1
$c_2$	1
$d$	$0.9 \sin(628t)$
$d_{max}$	0.9
$\mu$	0.5

Thus, we have

$$\begin{aligned} p^T &= (1 \ 1) \\ f &= \begin{pmatrix} 2x_1 \\ x_1 \end{pmatrix} \\ g &= \begin{pmatrix} 1 \\ 0 \end{pmatrix} \\ h &= \begin{pmatrix} 1 \\ 0 \end{pmatrix} \end{aligned}$$

The system plant,

$$\begin{aligned} \dot{x} &= \begin{pmatrix} 2 & 0 \\ 1 & 0 \end{pmatrix} x + \begin{pmatrix} 1 \\ 0 \end{pmatrix} u + \begin{pmatrix} 1 \\ 0 \end{pmatrix} d \\ \sigma &= (1 \ 1) x \end{aligned} \tag{2.1}$$

and the control law becomes

$$\begin{aligned} u(t) &= -3x_1 - (0.9 + 0.5)\text{sign}(\sigma) \\ &= -3x_1 - 1.4\text{sign}(\sigma) \end{aligned} \tag{2.2}$$

## 2.2 Simulation Results

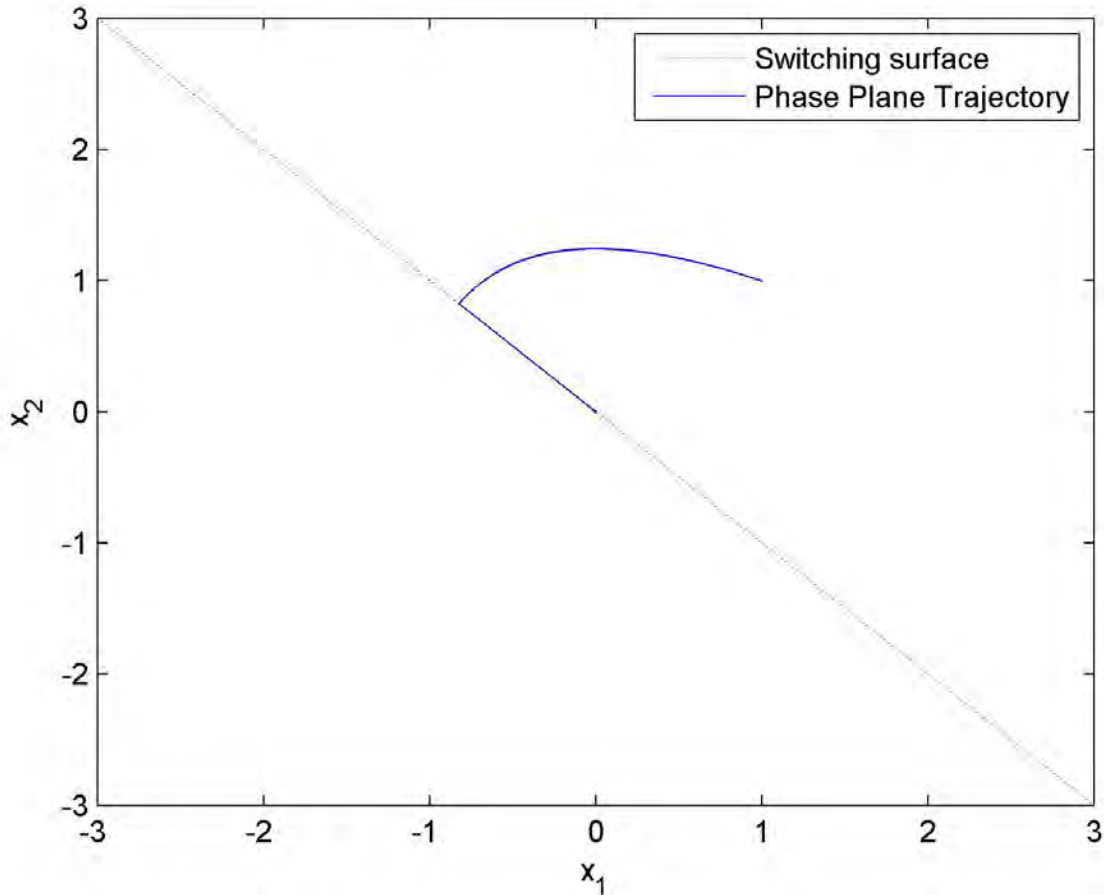

Figure 2.1: Phase plane trajectory of the system response for  $x_1(0) = x_2(0) = 1$  as initial condition.

### With Initial Condition, $x_1(0) = x_2(0) = 1$

Simulation is done using MATLAB and Simulink to verify the controller. The simulation results are shown in Fig. 2.1, Fig. 2.2 and Fig. 2.3. From the phase plane trajectory plot, we see that the trajectory starts from the initial points (1, 1), move towards the switching surface  $x_1 + x_2 = 0$ , then slide along the surface to reach the equilibrium point  $x = 0$ .



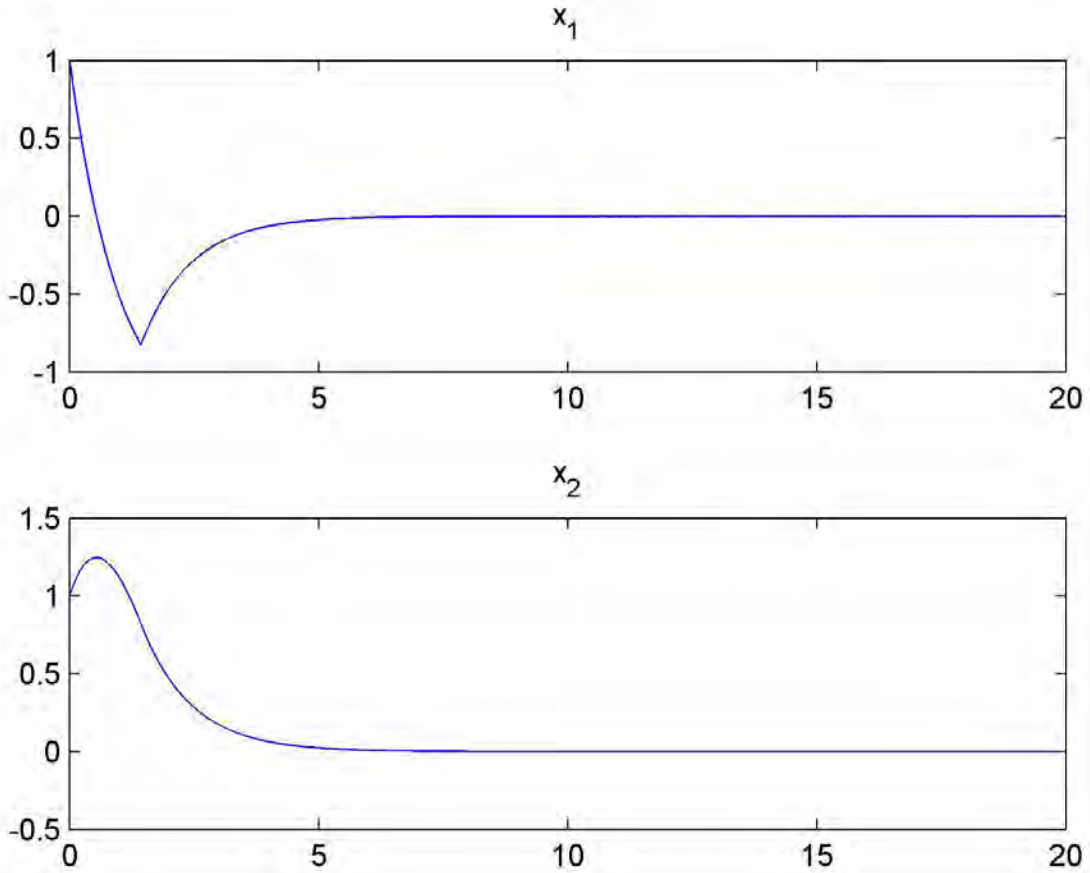

Figure 2.2: State  $x_1$  and  $x_2$  of the system response for  $x_1(0) = x_2(0) = 1$  as initial condition.

According to Fig. 2.2, we can see that both signal  $x_1$  and  $x_2$  reaches 0 after about 7 seconds. Also, noted from the  $x_1$  plot, we could see that the trajectory reaches the switching surface when the time is approximately  $t_\sigma = 1.4$  seconds.

However, for the control signal of the system, this control law has the drawback that the control signal chatters when the system trajectory is moving on the switching surface (refers Fig. 2.3). This is due to the use of a  $sign(\sigma)$  function in the control law, i.e.

$$u(t) = -3x_1 - 1.4sign(\sigma)$$

Judging from this control law, we note that when the switching surface  $\sigma = x_1 + x_2$  reaches 0, numerical quantization errors of digital processor might cause it fluctuate along 0. Thus, at one instant it might be a positive small number, and at another instant, a negative small number. Switching between positive and negative small number of  $\sigma$ , will cause the control signal,  $u(t)$ , to fluctuate along the envelope of the signal, with the fluctuation amplitude of 1.4 units, as confirmed from the plot.

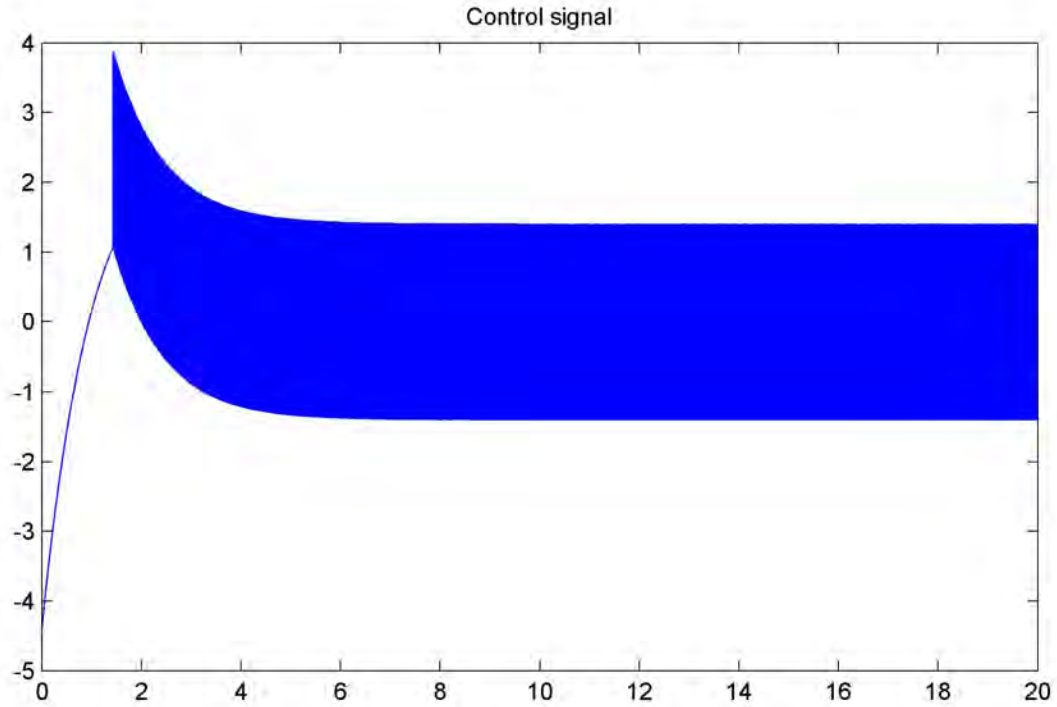

Figure 2.3: Control signal of the system response for  $x_1(0) = x_2(0) = 1$  as initial condition.

### With Other Initial Conditions, $x_1(0), x_2(0) \leq 2$

Simulation is done to the same controller with different initial conditions as shown in the table below:

$x_1(0)$	$x_2(0)$
-2	1
-2	0
-2	-1
-2	-2
2	2
2	1
2	0
2	-1

The simulation results are shown in Fig. 2.4, Fig. 2.5 and Fig. 2.6. As expected, regardless of the initial position, the controller manage to force the state  $x$  to 0 after some time. Also, we can notice that the further the initial condition is from the switching surface, the longest it takes to reach the surface. According to Fig. 2.6, chattering of control signal occurs after the phase plane trajectory reaches the switching surface for all the different initial conditions investigated.

The control signal chattering drawback can be improved or eliminated by simple modification of the control law. They will be discussed in detail in the next chapter.

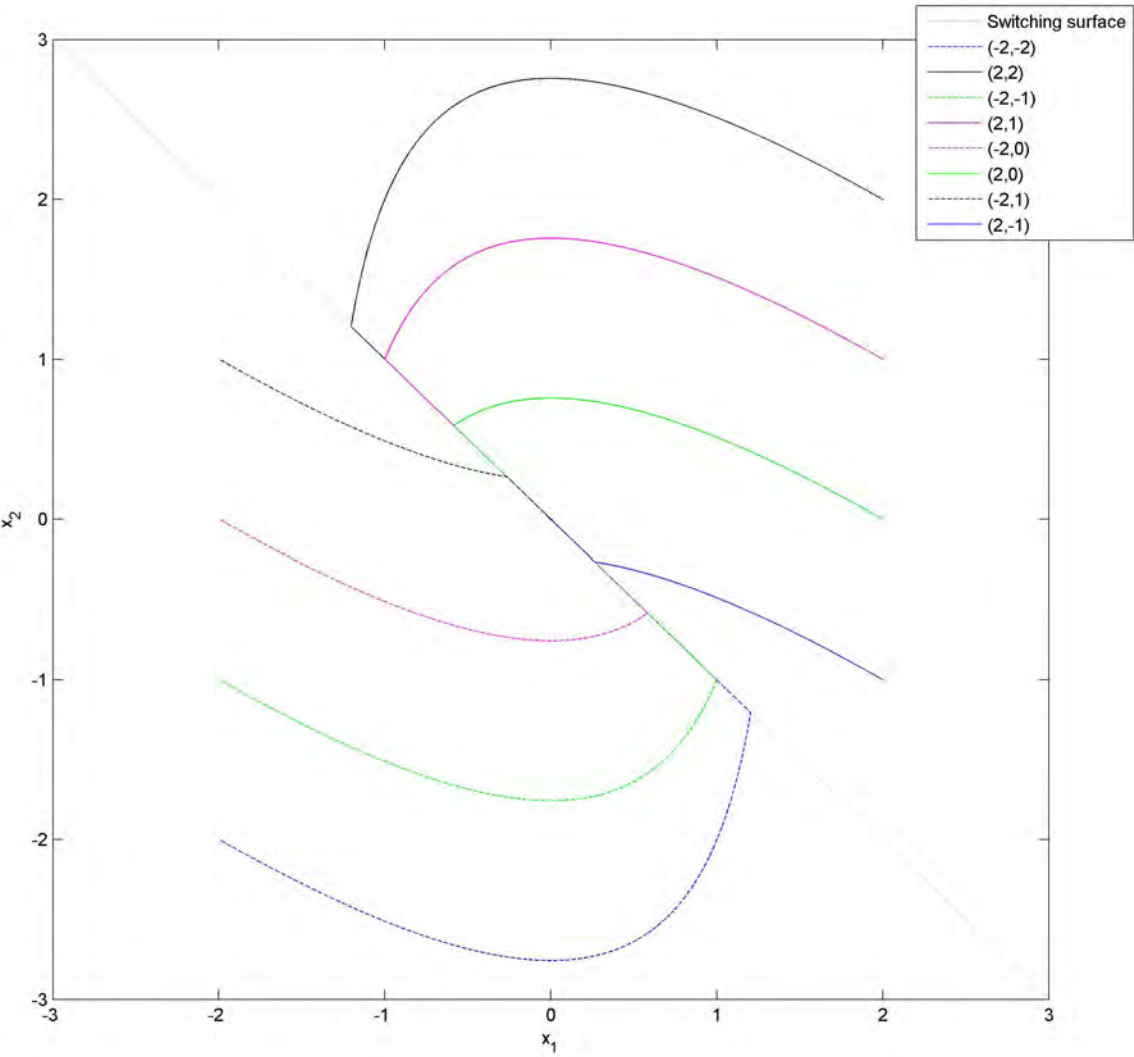

Figure 2.4: Phase plane trajectory of the system response for different  $x_1(0)$  and  $x_2(0)$  as initial conditions.

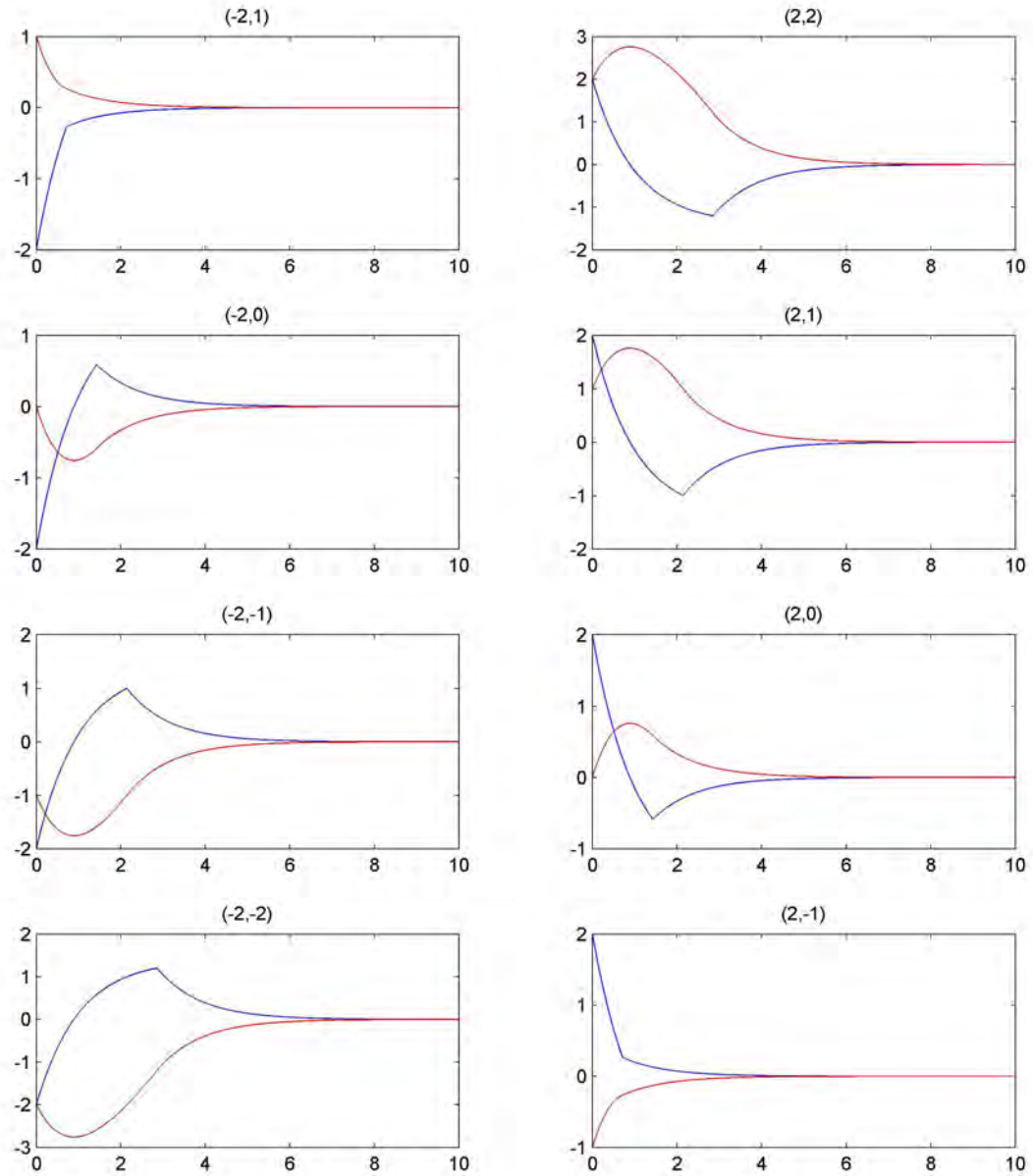

Figure 2.5: State  $x_1$  and  $x_2$  of the system response for different  $x_1(0)$  and  $x_2(0)$  as initial conditions. Blue line and red line correspond to  $x_1$  and  $x_2$  respectively.

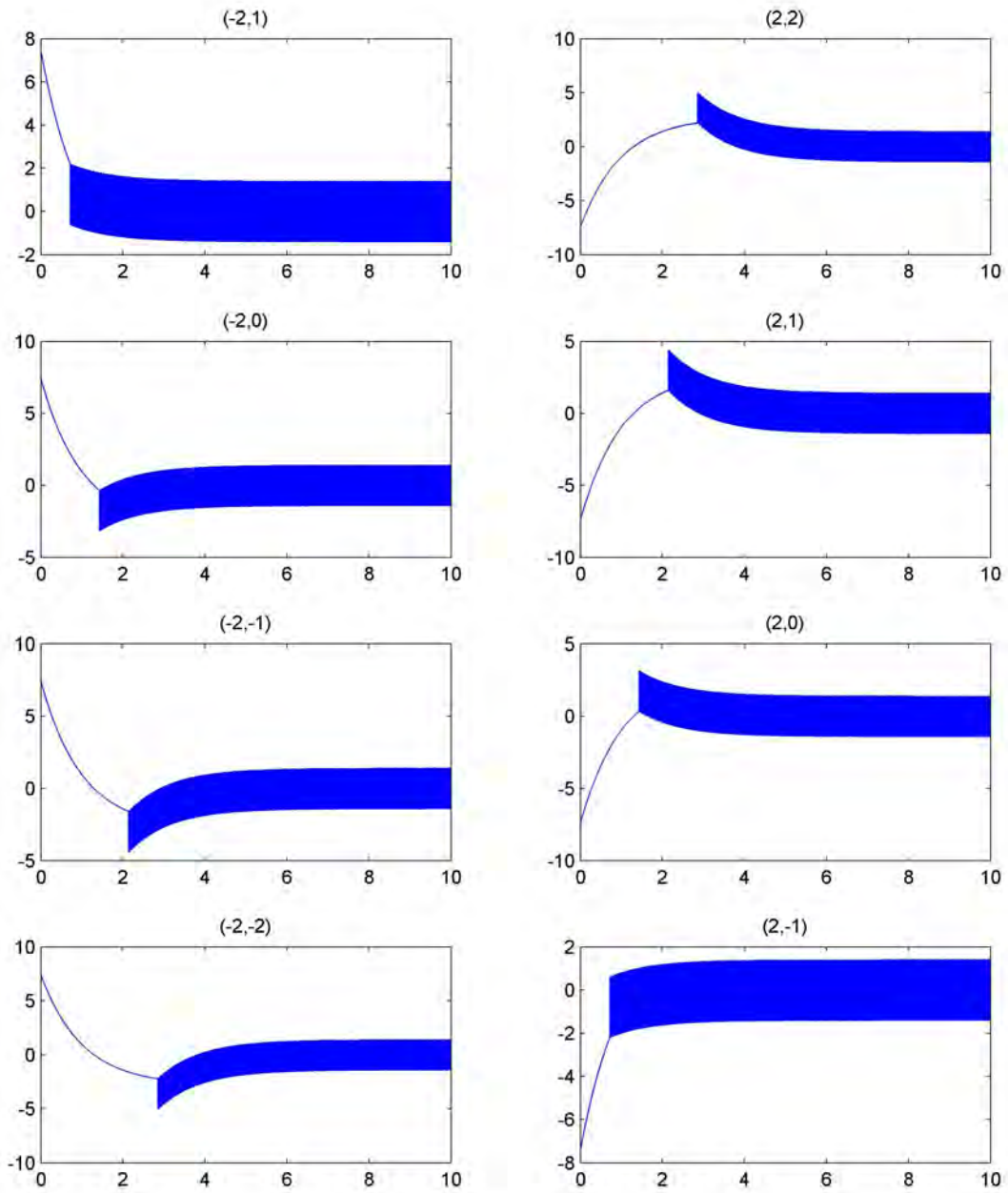

Figure 2.6: Control signal of the system response for different  $x_1(0)$  and  $x_2(0)$  as initial conditions.

# Chapter 3

## Smooth Control Law

The control law designed in the previous chapter has the drawback that the relay chatters, as shown in the simulation results. One way to avoid this is to make the relay characteristics smoother.

### 3.1 Control Law Design

In order to eliminate the chattering of the control signal, the *sign* function in the original control law,

$$u = -\frac{p^T f}{p^T g} - \frac{p^T h d_{max} + \mu}{p^T g} \text{sign}(\sigma(x))$$

is replaced by a *sat* function,

$$\text{sat}(\sigma, \varepsilon) = \begin{cases} 1 & \sigma > \varepsilon \\ \sigma/\varepsilon & -\varepsilon \leq \sigma \leq \varepsilon \\ -1 & \sigma < -\varepsilon \end{cases}$$

The control law is then

$$\begin{aligned} u &= -\frac{p^T f}{p^T g} - \frac{p^T h d_{max} + \mu}{p^T g} \text{sat}(\sigma(x), \varepsilon) \\ &= -3x_1 - 1.4 \text{sat}(\sigma(x), \varepsilon) \end{aligned} \tag{3.1}$$

### 3.2 Simulation

Simulation is carried out to investigate the effect of this smooth control law implemented.

**With**  $\varepsilon = 0.01$

For  $\varepsilon = 0.01$ , the control law becomes

$$u = -3x_1 - 1.4 \text{sat}(\sigma(x), 0.01) \tag{3.2}$$

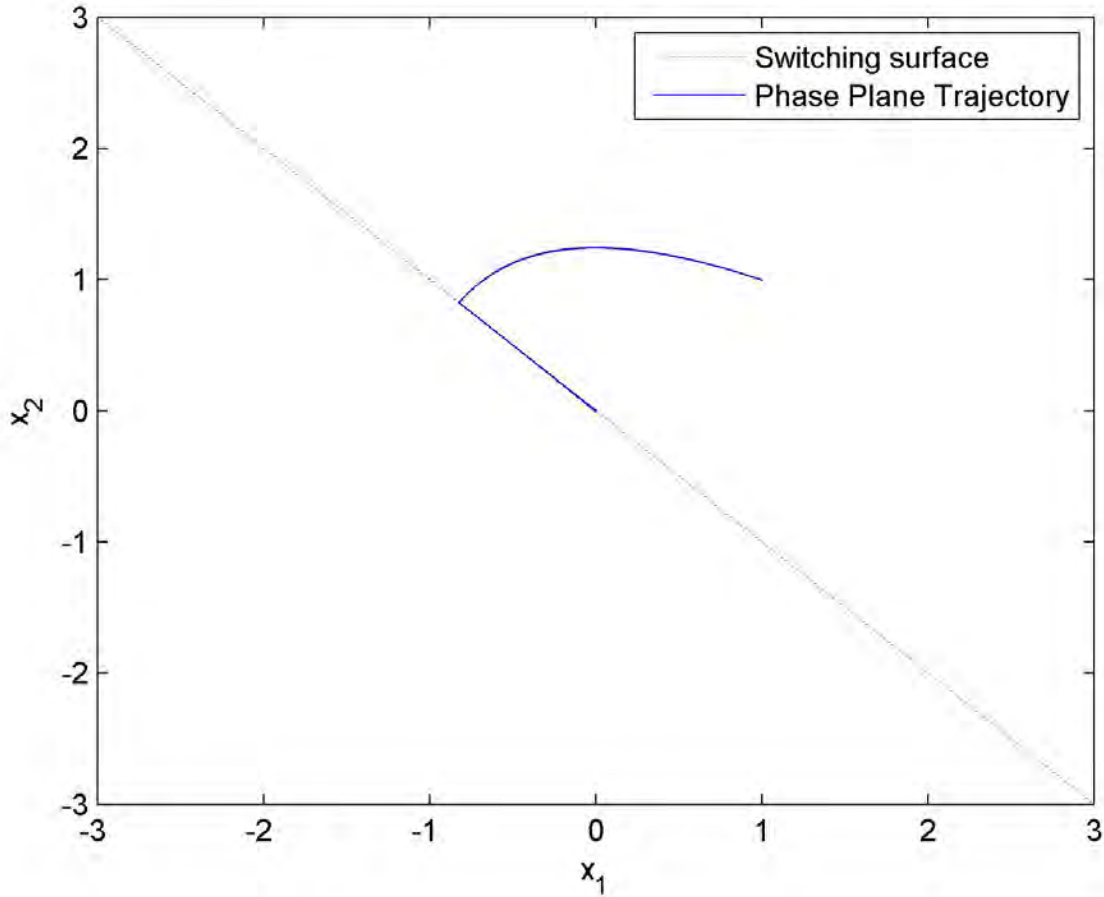

Figure 3.1: Phase plane trajectory of the system response with  $\varepsilon = 0.01$ .

The simulation results are shown in Fig. 3.1, Fig. 3.2, and Fig. 3.3. As we could observe, the controller works well as the trajectory will be driven back to the switching surface after some time. We can also see that  $t_\sigma$  of this system is approximately the same as the one in the previous chapter. However, looking at the control signal,  $u(t)$ , chattering of the signal still occurs at switching surface, although the magnitude of chattering is much smaller compare to the controller with *sign* function. This improvement has motivated me to further investigate the performance of the system with both larger and smaller  $\varepsilon$ .

### With $\varepsilon = 1$

In this section, the  $\varepsilon$  value is increased to 1. The plant is simulated and the phase plane trajectory and control signal are plotted in Fig. 3.4 and Fig. 3.5 respectively. From the Fig. 3.4, we notice that the trajectory takes longer time to reach the switching surface as compared with the previous case. For control signal wise, according to Fig. 3.5, the chattering problem has decreased significantly. When the response plot is zoomed, we can see that although chattering occurs, the magnitude of the chattering is in the order of  $10^{-3}$ ,

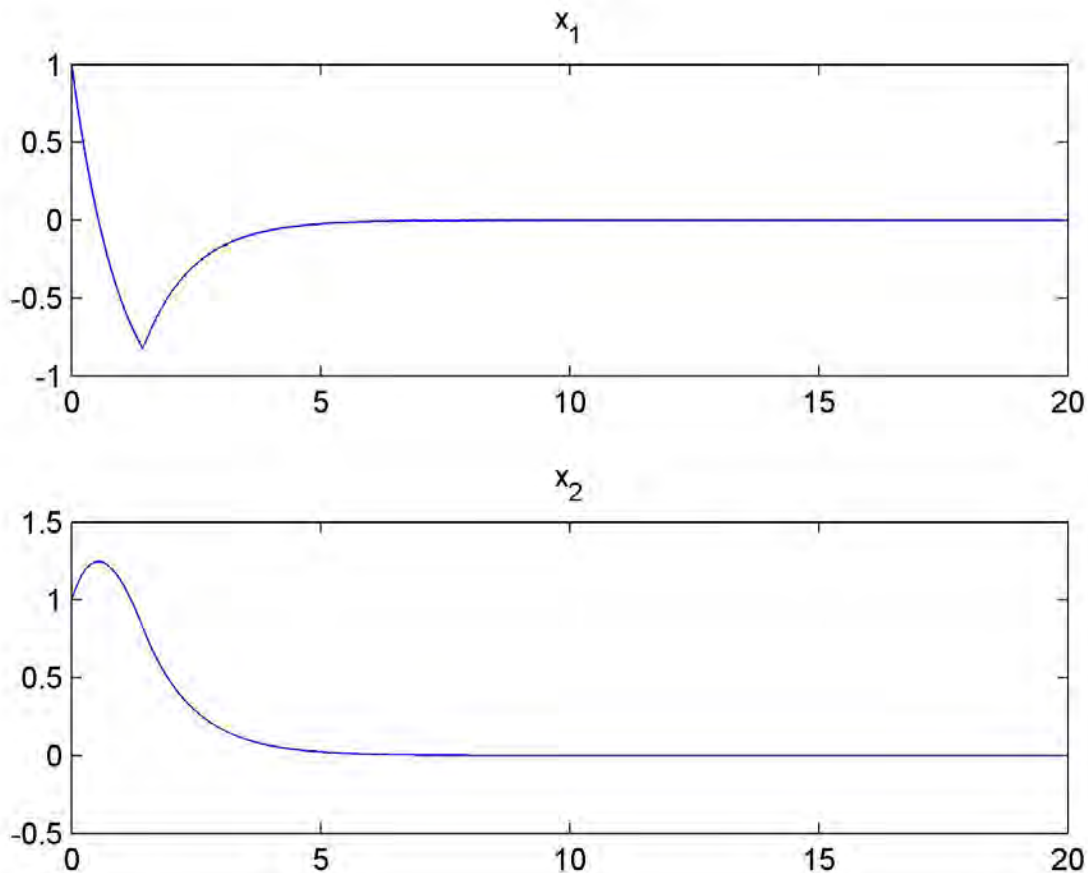

Figure 3.2: State  $x_1$  and  $x_2$  of the system response with  $\varepsilon = 0.01$ .

which is so small that it can be assumed 0.

### With $\varepsilon = 0.0001$

In this section, the  $\varepsilon$  value is decreased to 0.0001. The plant is simulated and the phase plane trajectory and control signal are plotted in Fig. 3.6 and Fig. 3.7 respectively. From the Fig. 3.6, we notice that the trajectory reaches the switching surface faster compared with the previous case of  $\varepsilon = 1$ . For control signal wise, according to Fig. 3.7, the chattering problem occurs again. When the response plot is zoomed, we can see that the magnitude of the chattering is about 1, which is still smaller than the chattering amplitude of the system with *sign* function.

### Conclusion

With the simulation, we can conclude that, by replacing the *sign* function to the *sat* function in the control law, we could minimize the chattering drawbacks of the control signal. Although the chattering is not completely eliminated, we could control the amplitude of it



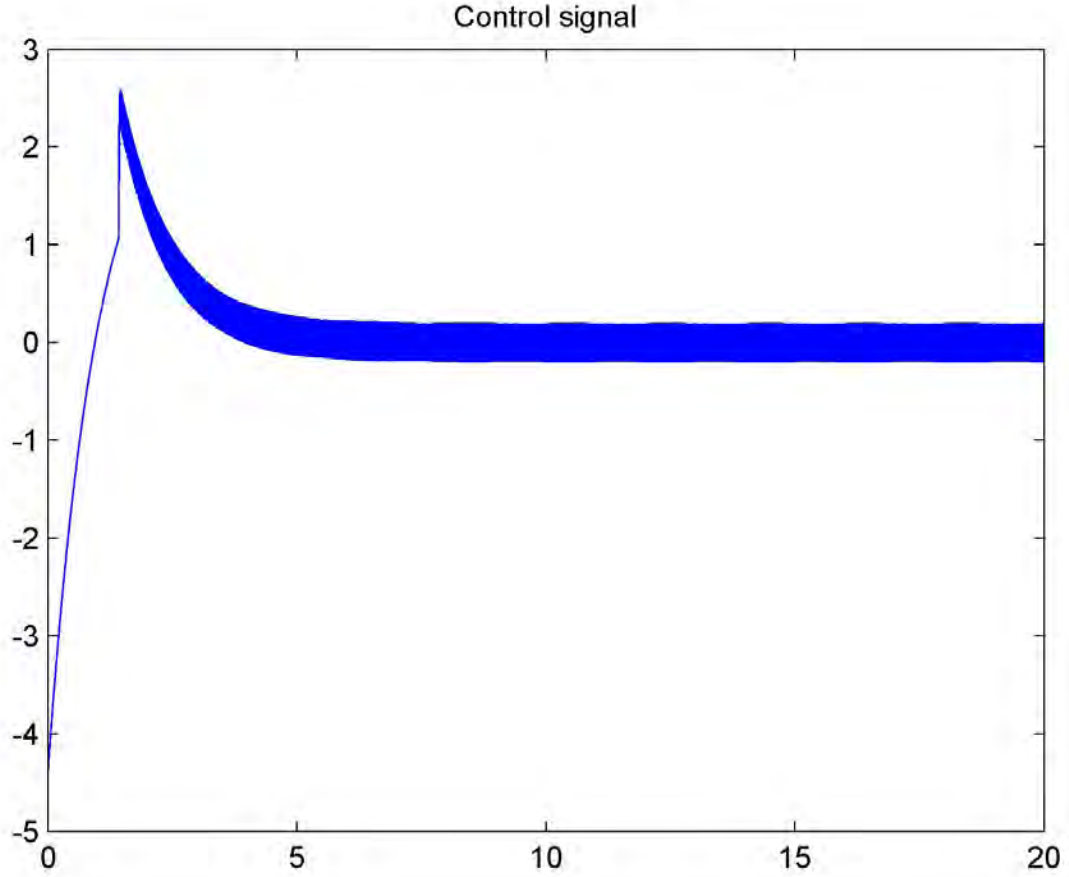

Figure 3.3: Control signal of the system response with  $\varepsilon = 0.01$ .

by varying the parameter  $\varepsilon$ . The lower the value of  $\varepsilon$  is, the *sat* function will approximate *sign* function better, and thus chattering occurs in higher magnitude. However, when the value of  $\varepsilon$  is lowered, the chattering decreases, but it has a trade off in terms of performance of the system.

Theoretically, by replacing the *sign* function to a *sat* function with a fixed  $\varepsilon$ , we have the Lyapunov function

$$\dot{V}(x) = \sigma(0.9 \sin(628t)) - \sigma(\text{sat}(\sigma, \varepsilon)) \quad (1.4) \quad (3.3)$$

When  $\sigma$  is at the linear zone,  $\sigma \leq \varepsilon$  in general, we have

$$\dot{V}(x) = \sigma(0.9 \sin(628t)) - \frac{\sigma^2}{\varepsilon} \quad (1.4) \quad (3.4)$$

As we can see, for smaller  $\varepsilon$ , the value of  $\dot{V}$  is more negative. Thus the trajectory will reach the switching surface relatively faster.

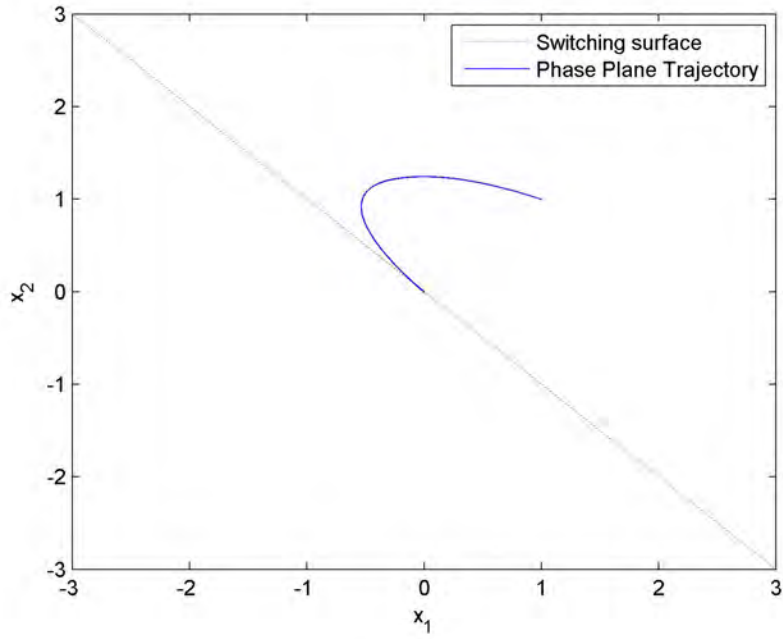

Figure 3.4: Phase plane trajectory of the system response with  $\varepsilon = 1$ .

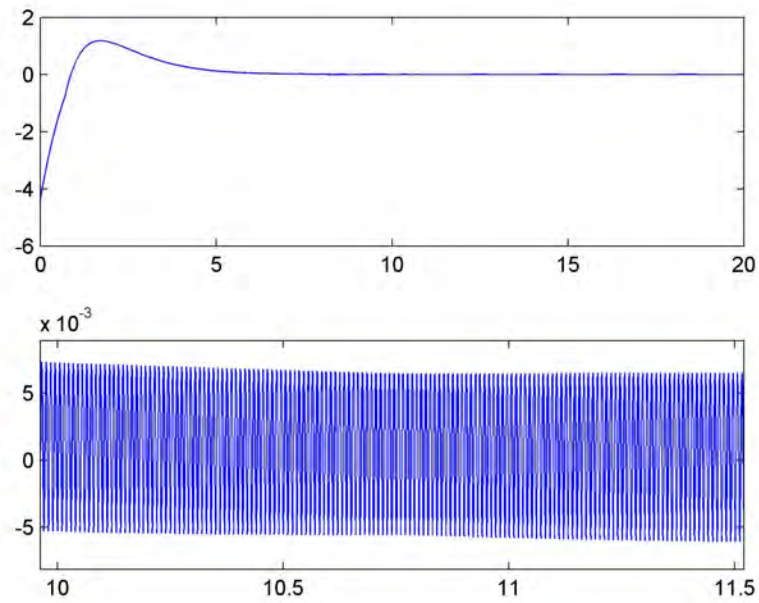

Figure 3.5: Control signal of the system response with  $\varepsilon = 1$ .

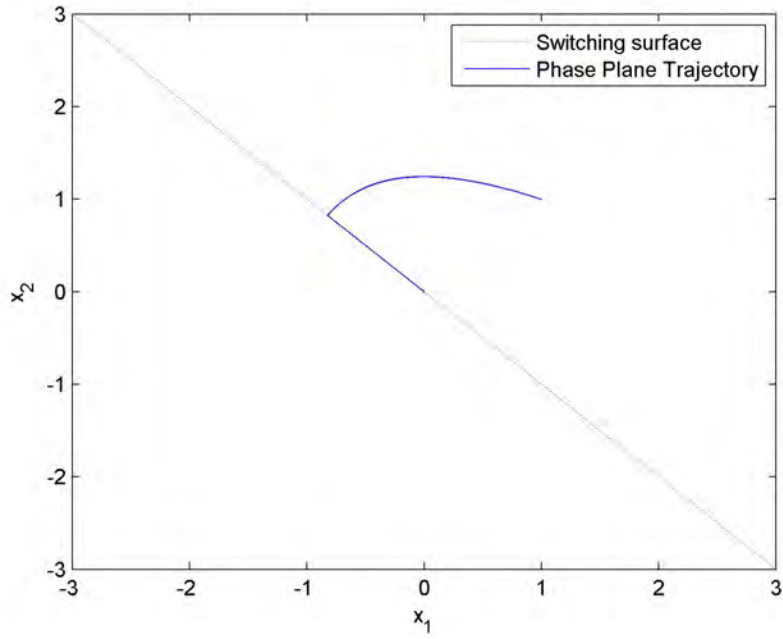

Figure 3.6: Phase plane trajectory of the system response with  $\varepsilon = 0.0001$ .

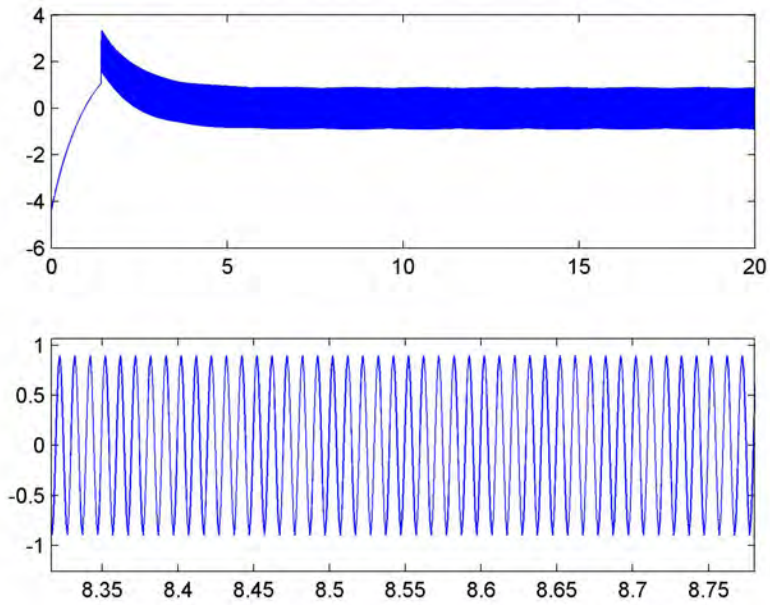

Figure 3.7: Control signal of the system response with  $\varepsilon = 0.0001$ .

# Chapter 4

## Source Codes

The following MATLAB and Simulink files are used in this project to simulate the sliding mode controller:

1. sliding\_plot.m
2. sliding\_plot\_10.m
3. CA2\_sign.mdl
4. CA2\_sat.mdl

## sliding\_plot.m

This is a MATLAB script to plot the input signal,  $u(t)$ , states  $x_1$  and  $x_2$ , and the phase plane trajectory of the system.

---

```
% Define time (20 seconds with 1000Hz sampling freq)
t = linspace(0,20,20001);
ppt = [-3 3];
pptp = [3 -3];

% u(t)
figure(1);
plot(t,u);
title('Control signal');

% x_1 and x_2
figure(2);
subplot(2,1,1); plot(t, x(:,1)); title('x_1');
subplot(2,1,2); plot(t, x(:,2)); title('x_2');

% Phase Plane Trajectory
figure(3);
plot(ppt,pptp,'r:',x(:,1),x(:,2),'b-');
xlabel('x_1'); ylabel('x_2');
legend('Switching surface','Phase Plane Trajectory');
```

---

## sliding\_plot\_10.m

This is a MATLAB script to plot the input signal,  $u(t)$ , states  $x_1$  and  $x_2$ , and the phase plane trajectory of the system of 10 different initial conditions.

---

```
% Define time (10 seconds with 1000Hz sampling freq)
t = linspace(0,10,10001); ppt = [-3 3]; pptp = [3 -3];

figure(1);
subplot(4,2,1); plot(t,u1); title('(-2,1)');
subplot(4,2,3); plot(t,u2); title('(-2,0)');
subplot(4,2,5); plot(t,u3); title('(-2,-1)');
subplot(4,2,7); plot(t,u4); title('(-2,-2)');
subplot(4,2,2); plot(t,u5); title('(2,2)');
subplot(4,2,4); plot(t,u6); title('(2,1)');
subplot(4,2,6); plot(t,u7); title('(2,0)');
subplot(4,2,8); plot(t,u8); title('(2,-1)');

figure(2);
subplot(4,2,1); plot(t, x1(:,1),'b-',t,x1(:,2),'r-'); title('(-2,1)');
subplot(4,2,3); plot(t, x2(:,1),'b-',t,x2(:,2),'r-'); title('(-2,0)');
subplot(4,2,5); plot(t, x3(:,1),'b-',t,x3(:,2),'r-'); title('(-2,-1)');
subplot(4,2,7); plot(t, x4(:,1),'b-',t,x4(:,2),'r-'); title('(-2,-2)');
subplot(4,2,2); plot(t, x5(:,1),'b-',t,x5(:,2),'r-'); title('(2,2)');
subplot(4,2,4); plot(t, x6(:,1),'b-',t,x6(:,2),'r-'); title('(2,1)');
subplot(4,2,6); plot(t, x7(:,1),'b-',t,x7(:,2),'r-'); title('(2,0)');
subplot(4,2,8); plot(t, x8(:,1),'b-',t,x8(:,2),'r-'); title('(2,-1)');

figure(3);
plot(ppt,pptp,'r:'); hold on;
plot(x4(:,1),x4(:,2),'b--');
plot(x5(:,1),x5(:,2),'k-');
plot(x3(:,1),x3(:,2),'g--');
plot(x6(:,1),x6(:,2),'m-');
plot(x2(:,1),x2(:,2),'m--');
plot(x7(:,1),x7(:,2),'g-');
plot(x1(:,1),x1(:,2),'k--');
plot(x8(:,1),x8(:,2),'b-');
hold off; xlabel('x_1'); ylabel('x_2');
legend('Switching surface', '(-2,-2)', '(2,2)', '(-2,-1)',
      '(2,1)', '(-2,0)', '(2,0)', '(-2,1)', '(2,-1)');
```

---

# CA2\_sign.mdl

This is a Simulink block diagram for the sliding mode control using *sign* function.

---

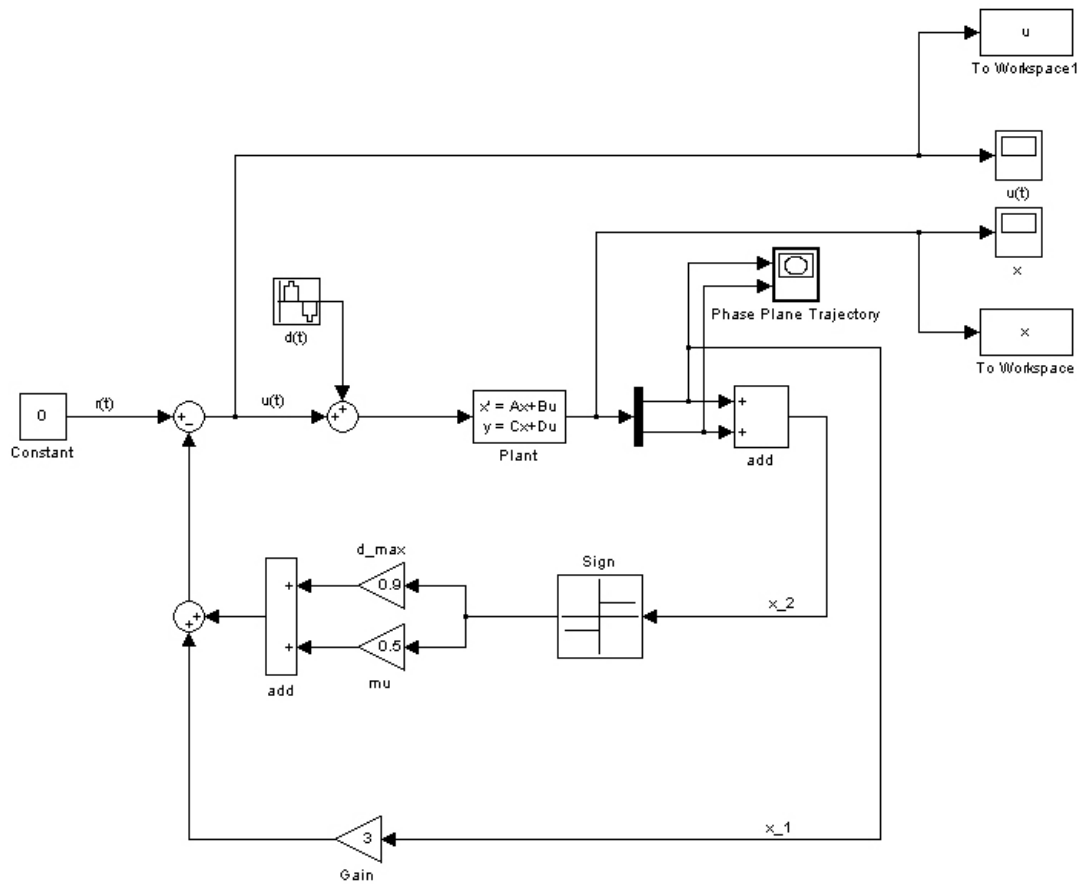

# CA2\_sat.mdl

This is a Simulink block diagram for the sliding mode control using *sat* function.

